

A demountable cryogenic feedthrough for plastic optical fibers

J. S. Butterworth,^{a)} C. R. Brome, P. R. Huffman, C. E. H. Mattoni,^{b)} D. N. McKinsey, and J. M. Doyle

Department of Physics, Harvard University, Cambridge, Massachusetts 02138

(Received 16 June 1998; accepted for publication 8 July 1998)

A superfluid-helium-tight optical fiber feedthrough has been developed. Heat shrinkable Kynar provides a removable seal around a plastic optical fiber. The seal preserves the continuity of the fiber and is reliable after repeated thermal cycles. © 1998 American Institute of Physics. [S0034-6748(98)00210-X]

A variety of experiments rely on the room temperature detection of light produced inside a low temperature apparatus. Optical fibers offer a convenient method for transporting light from a cryogenic region to room temperature. Crucial to the success of such a technique is the development of reliable feedthroughs. One such feedthrough which we find to work well at room temperature is described in the literature.¹ In the case of glass optical fibers, cryogenic feedthrough techniques using solder exist.²

We have developed a fiber-based detection system for an experiment to demonstrate the magnetic trapping of ultracold neutrons in a 100 mK ⁴He bath.³ As part of that system, a demountable, superfluid-helium-tight vacuum feedthrough for multiclad polystyrene optical fibers was necessary.⁴

We began our development effort by trying an epoxy-based feedthrough. A common design for cryogenic electrical feedthroughs uses epoxy to form a seal between the wires and the vacuum can through which they pass.⁵ Cryogenic fiber feedthroughs of this type using Stycast 1266⁶ were tested but did not have long-term reliability. We have not found a satisfactory alternative epoxy. Such an epoxy must have a thermal contraction well matched to that of the fiber and must adhere well to the fluoropolymer cladding. Epoxy-sealed feedthroughs are also less desirable because once assembled they cannot subsequently be dismantled.

We have developed a feedthrough that relies on the thermal contraction of Kynar [polyvinylidene fluoride (PVDF)] to ensure a reliable seal to both the optical fiber and the vacuum can. We expect that fluoropolymers other than Kynar could be substituted.⁷ The design of the feedthrough is shown in Fig. 1. Heat shrinkable Kynar tubing (2 mm initial inner diameter)⁸ is used to seal the optical fiber to the stainless steel tube, which is brazed to the vacuum can. The metal tube (1.6 mm outer diameter, 0.2 mm wall) is chosen such that the 0.8 mm fiber easily passes through.

The Kynar sleeve is formed prior to making the seal. This avoids heating the polystyrene fiber which has a low softening temperature. A copper wire is drawn to a diameter approximately 5–10 μm larger than that of the fiber by stretching a slightly oversized wire by hand. A section of the

wire with the desired diameter is chosen and inserted through the stainless steel tube, protruding at least a few centimeters out of both sides. A thin layer of Dow Corning vacuum grease⁹ is applied to both the wire and the tube to facilitate removal of the Kynar after heating. A 25 mm length of Kynar tubing is slid over the assembly until it equally covers the tube and the wire. The Kynar sleeve is formed by heating it with hot air (and therefore shrinking it onto the wire). The wire and tube are then removed.

Final assembly now takes place. A small amount of vacuum grease is applied to both the fiber and the stainless tube. The Kynar is slid along the fiber, while continuously rotating the former to avoid binding. The exact position of the fiber can be adjusted before sliding the Kynar onto the metal tube to complete the feedthrough.

The feedthroughs are found to work reliably after repeated thermal cycling from 100 mK to 300 K. They have been disassembled and reused several times with no deterioration of performance, provided that prior to each reassembly vacuum grease is applied to both the metal tube and fiber. Although the feedthrough was originally designed to over-

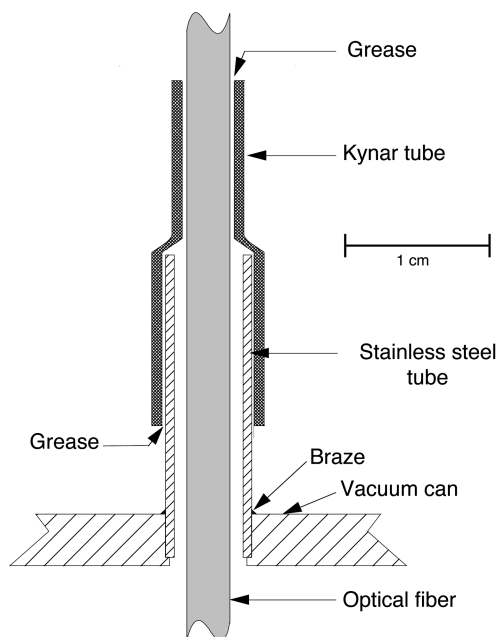

FIG. 1. Vacuum feedthrough assembly.

^{a)}Present address: Institut Laue—Langevin, B.P. 156, 38042 Grenoble, France.

^{b)}Electronic mail: carlo@jsbach.harvard.edu

come problems associated with the large thermal contraction of polystyrene fibers, it is expected to work equally well with other kinds of optical fibers, metal wires, and coaxial leads.

This work was supported in part by the National Science Foundation under Grant No. PHY-9424278.

¹E. R. I. Abraham and E. A. Cornell, *Appl. Opt.* **37**, 1762 (1998).

²G. A. Williams and R. E. Packard, *Rev. Sci. Instrum.* **45**, 1029 (1974).

³J. M. Doyle and S. K. Lamoreaux, *Europhys. Lett.* **26**, 253 (1994).

⁴S-type Y-11M fibers supplied by Kuraray International Corporation, New York, NY.

⁵F. Mathu and H. C. Meijer, *Cryogenics* **22**, 428 (1982).

⁶Stycast 1266 manufactured by Emerson and Cuming, Woburn, MA.

⁷One feedthrough using Teflon heat shrink instead of Kynar was made and tested. Teflon heat shrink, McMaster Carr Supply Company, New Brunswick, NJ.

⁸Voltrex brand KYS-004 manufactured by SPC Technology, Chicago, IL.

⁹Dow Corning Corp., Midland, MI.